SFP-10G-T

Overview

The SFP-10G-T copper transceiver module is a high performance integrated duplex data link for bi-directional communication over copper cable. It is specifically designed for high speed communication links that require 10 Gigabit Ethernet over Cat 6a/7 cable. This is the first SFP+ transceiver that offers 10 Gb/s communication over this type of media.

Product Features

- ▶ Supports Links up to 30m using Cat 6a/7 Cable
- ▶ SFF-8431 and SFF-8432 MSA Compliant
- ▶ IEEE 802.3az Compliant
- ▶ Low Power Consumption (2.5W max @ 30m)
- ▶ Fast Retrain EMI Cancellation Algorithm
- ▶ Low EMI Emissions
- ▶ I2C 2 Wire Serial Interface for Serial Id and Phy Registers
- ▶ Auto-negotiates with other 10GBase-T-NC PHYs
- ▶ Automatic Detection and Correction of Wiring and Polarity Swaps
- ▶ Robust Die Cast Housing
- ▶ Bail Latch Style ejector mechanism
- ▶ Unshielded and Shielded cable support

General Specifications

<i>Parameter</i>	<i>Symbol</i>	<i>Min</i>	<i>Typ</i>	<i>Max</i>	<i>Unit</i>	<i>Remarks</i>
Bit Error Rate	<i>BER</i>			10 ⁻¹²		
Operating Temperature	<i>T_{OP}</i>	0		70	°C	Case temperature
Storage Temperature	<i>T_{STO}</i>	-40		85	°C	Ambient temperature
Operating Humidity	-	5		95	%	Non condensing
Power @30m	<i>I_S</i>		2.3	2.5	W	
Input Voltage	<i>V_{CC}</i>	3	3.3	3.6	V	

PCB Layout Recommendation

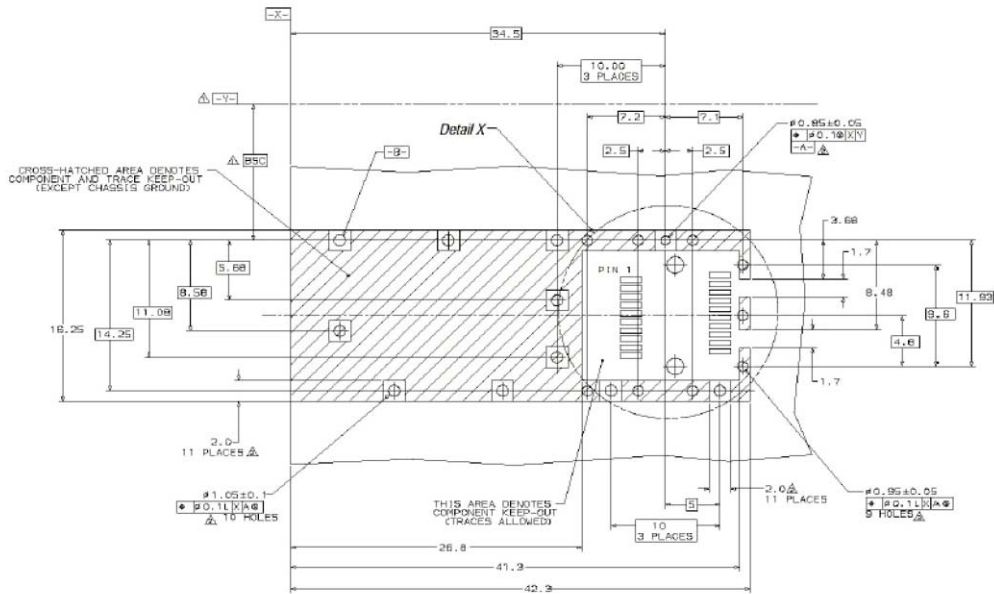

- △ Datum and Basic Dimension Established by Customer
- △ Rads and Vias are Chassis Ground, 11 Places
- △ Through Holes are Unplated

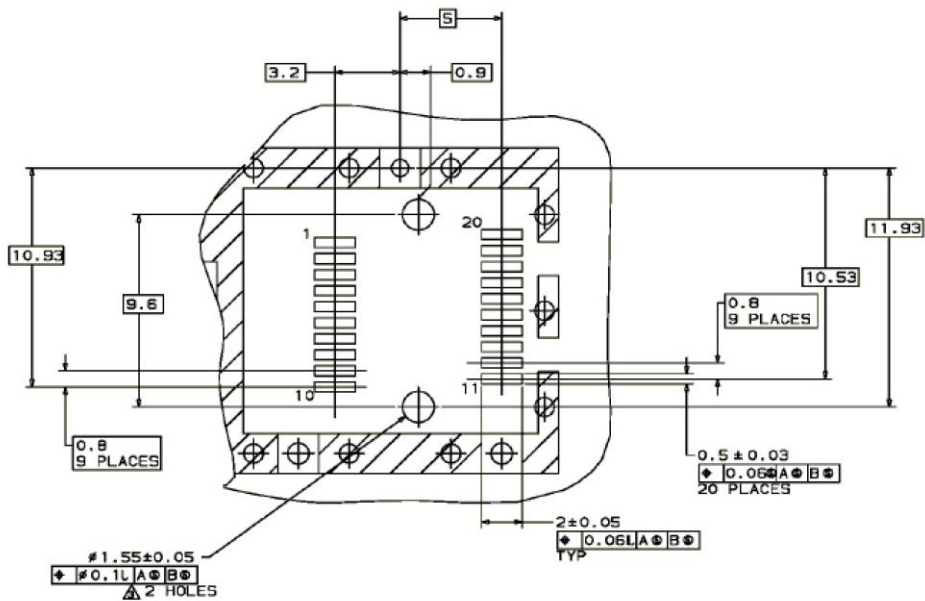

Electrical Pad Layout

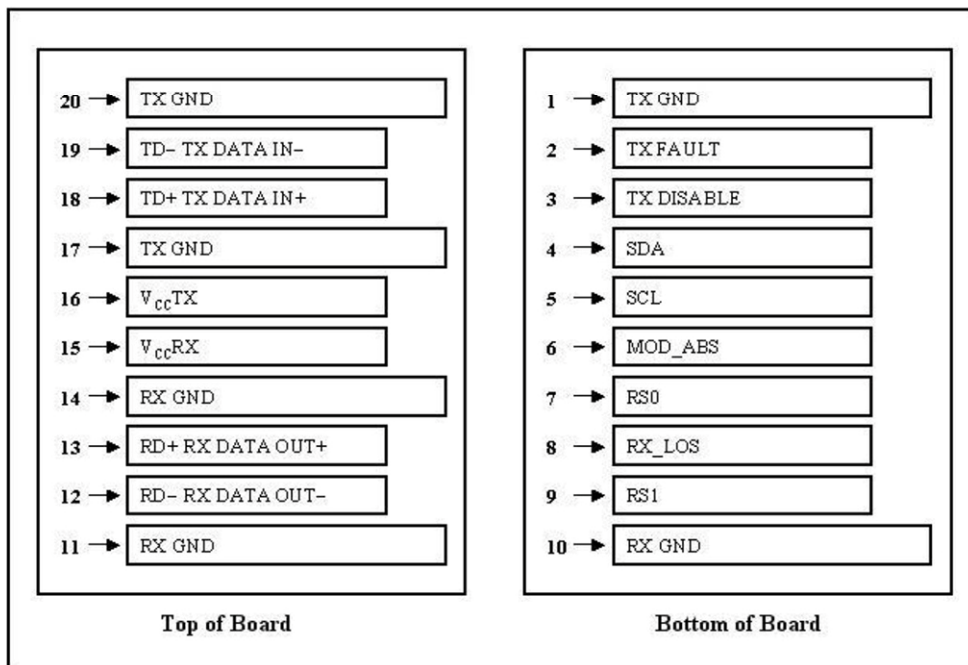
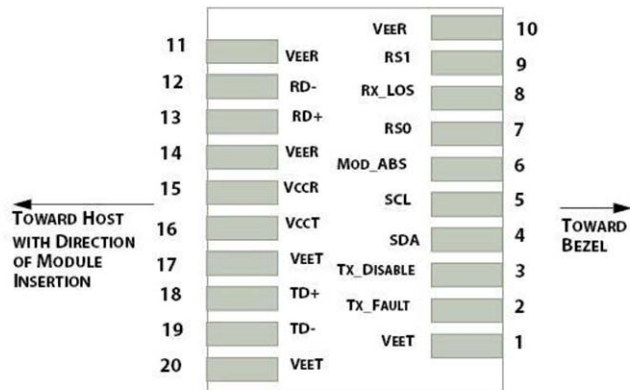

Pin Assignment

PIN #	Symbol	Description	Remarks
1	V _{EET}	Transmitter ground (common with receiver ground)	Circuit ground is isolated from chassis ground
2	I _{FAULT}	Transmitter Fault.	
3	T _{DIS}	Transmitter Disable. Laser output disable on high or open	Disabled: T _{DIS} >2V or open Enabled: T _{DIS} <0.8V
4	SDA	Data line for serial ID	Should Be pulled up with 4.7k – 10k ohm on host board to a voltage between 2V and 3.6V
5	SCL	Clock line for serial ID	
6	MOD_ABS	Module Absent. Grounded within the module	
7	RS0	No connection required	
8	LOS	Loss of Signal indication. Logic 0 indicates normal operation	LOS is open collector output
9	RS1	No connection required	
10	V _{EER}	Receiver ground (common with transmitter ground)	Circuit ground is isolated from chassis ground
11	V _{EER}	Receiver ground (common with transmitter ground)	
12	RD-	Receiver Inverted DATA out. AC coupled	
13	RD+	Receiver Non-inverted DATA out. AC coupled	
14	V _{EER}	Receiver ground (common with transmitter ground)	Circuit ground is isolated from chassis ground
15	V _{CCR}	Receiver power supply	
16	V _{CCT}	Transmitter power supply	
17	V _{EET}	Transmitter ground (common with receiver ground)	Circuit ground is connected to chassis ground
18	TD+	Transmitter Non-Inverted DATA in. AC coupled	
19	TD-	Transmitter Inverted DATA in. AC coupled	
20	V _{EET}	Transmitter ground (common with receiver ground)	Circuit ground is connected to chassis ground

References

1. IEEE standard 802.3ae. IEEE Standard Department, 2005.
2. Enhanced 8.5 and 10 Gigabit Small Form Factor Pluggable Module "SFP+" – SFF-8431
3. Digital Diagnostics Monitoring Interface for Optical Transceivers – SFF-8472

RJ45 Connector

RJ45 connector shall support shielded and unshielded cables. Also, the connector is mechanically robust enough and designed to prevent loss of link, when the cable is positioned or moves in different angles. The connector shall pass the "wiggle" RJ45 connector operational stress test. During the test, after the cable is plugged in, the cable is moved in circle to cover all 360 deg in the vertical plane, while the data traffic is on. There shall be no link or data loss.

Latch Requirements

The SFP transceiver latch should be mechanically robust and designed to prevent unintentional unlatching during insertion or extraction of the transceiver cable. The transceiver is designed with a "Bail type ejector latch mechanism" that allows the SFP module to be easily released from the cage, when the adjacent SFP ports in both rows are also populated and regardless of whether the SFP module is placed in the lower or upper row. The latch shall also pass the "wiggle" RJ45 connector stress test.

Measurement	Minimum	Maximum	Units	Comments
SFP transceiver insertion	N/A	18	Newtons	Measure without the force from any cage kick out springs. Module to be inserted into nominal cage.
SFP transceiver extraction	N/A	12.5	Newtons	Measure without the force from any cage kick out springs. Module to be inserted into nominal cage.
SFP transceiver retention	90	170	Newtons	No functional damage to module below 90N..
Insertion/removal cycles, SFP transceiver	50	N/A	Cycles	No functional damage to module, cage or connector

Dimensions

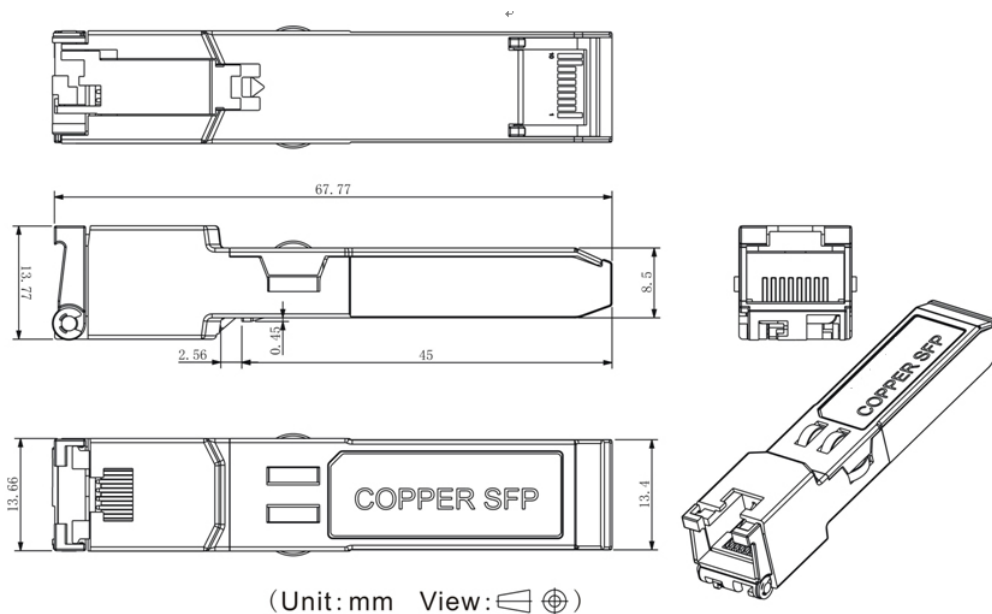

Figure 4, Mechanical Diagram of Copper SFP